

# 2-WAY FIT™ READY TRANSFORMATION PROCEDURE

UNIT	REVISION	DESCRIPTION
ROAD WHEELS - DISC BRAKE	02 - 08 /2018	PROCEDURE FOR TRANSFORMING THE WHEELS INTO THE TUBELESS READY VERSION
PRODUCTS TO WHICH THIS PROCEDURE APPLIES		
SCIROCCO DB		<b>PAG.1</b>

This procedure transforms **SCIROCCO DB** wheels (designed to be used with a clincher tyre and inner tube) into Tubeless Ready wheels (i.e. with a Tubeless Easy tyre, no inner tube and compulsory use of a sealant liquid).

To ensure the correct transformation of the wheels, it is obligatory to respect the procedure explained below, using the following components:

Tyres:	TUBELESS EASY-type SCHWALBE for E-Road, Road and Gravel applications (only the products included in the table on p. 6)
RIM WIDTH (mm)	MINIMUM CLINCHER WIDTH (MM)
<b>19c</b>	<b>23</b>
Schwalbe Rim Band:	<b>10 m x 23 mm, Art.-No. 887023</b> for 19c rims
Campagnolo tubeless valve	code VA-2WF44
Sealant liquid	Schwalbe Doc Blue

## DANGER!

**If this procedure is not followed, the tyre may break away from the rim and cause accidents, injury or even death.**

### Please note

In the event of a puncture consequently requiring the use of an inner tube, for the tyre to be correctly mounted you cannot use a portable mini-pump but must use a CO2 canister.

- Remove the original rim tape from the wheels, if present, using a screwdriver to separate it from the rim (Fig.1).

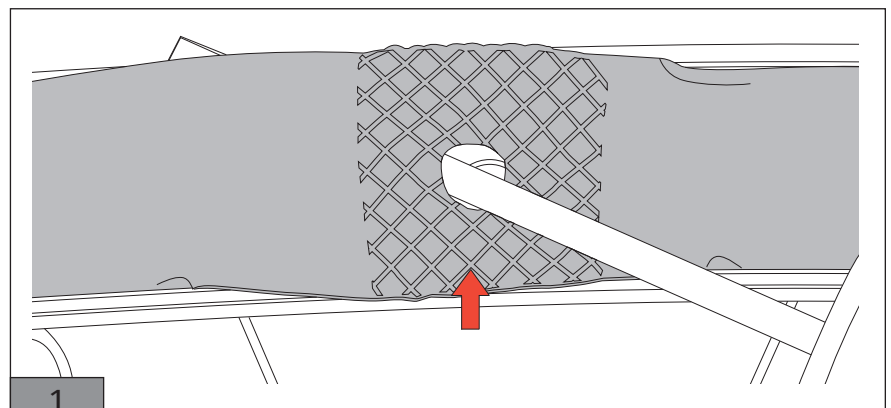

## 2-WAY FIT™ READY TRANSFORMATION PROCEDURE

UNIT	REVISION	DESCRIPTION
ROAD WHEELS - DISC BRAKE	02 - 08 /2018	PROCEDURE FOR TRANSFORMING THE WHEELS INTO THE TUBELESS READY VERSION
PRODUCTS TO WHICH THIS PROCEDURE APPLIES		
SCIROCCO DB		

PAG.2

- Using a cloth and some isopropyl alcohol, clean and degrease the wheel rim thoroughly, cleaning along the entire inner well and the inner walls of the rim, which will be in contact with the tyre beads (Fig. 2).

- Start applying the tape between the second and third spoke nipples (A - Fig. 3) after the valve hole (X - Fig. 3). Start applying the tape from A and move towards the valve hole.

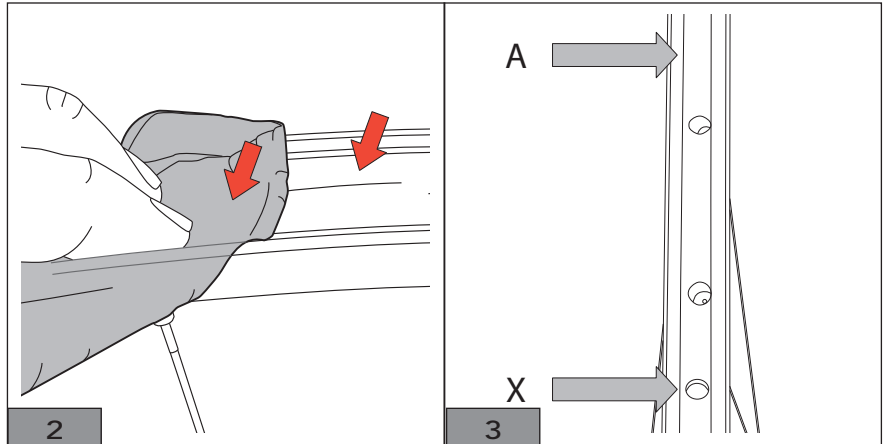

- Apply the tape carefully, ensuring that the entire length including the initial part adheres fully to the rim, pressing well with the fingers or with a plastic tool (Fig. 4). If necessary, cut off the initial part of the tape if it is not correctly adhered to the rim.

- Gradually unroll the tape, applying it around the circumference of the rim. Keep the tape taut and press it into the centre well, ensuring it is properly centred between the inner walls of the rim (Fig. 5).

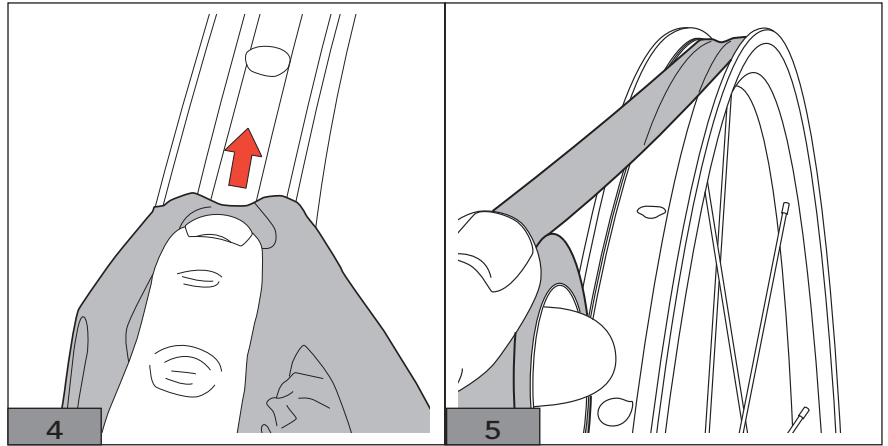

**⚠ WARNING!**

It is extremely important that the full length of the tape applied adheres completely to the centre and does not cover any part of the inner walls of the rim, which will be in contact with the tyre beads. This is to prevent the tyre bead detaching from the wheel during inflation or use, which could cause accidents and lead to severe or even fatal injury (Fig. 6 / Fig. 7).

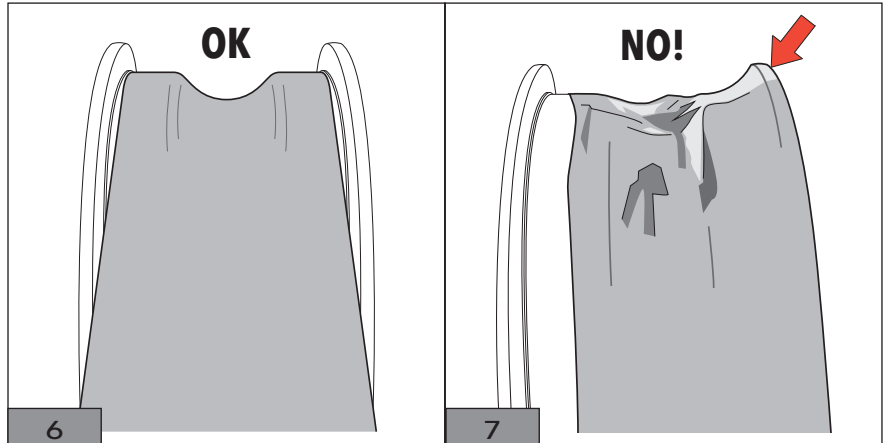

## 2-WAY FIT™ READY TRANSFORMATION PROCEDURE

UNIT	REVISION	DESCRIPTION
ROAD WHEELS - DISC BRAKE	02 - 08 /2018	PROCEDURE FOR TRANSFORMING THE WHEELS INTO THE TUBELESS READY VERSION
PRODUCTS TO WHICH THIS PROCEDURE APPLIES		
SCIROCCO DB		<b>PAG.3</b>

- Once the tape has reached the valve hole, continue applying tape to cover another 2 spoke nipples, then cut with scissors and adhere perfectly to the overlapped length of tape. (Fig. 8).

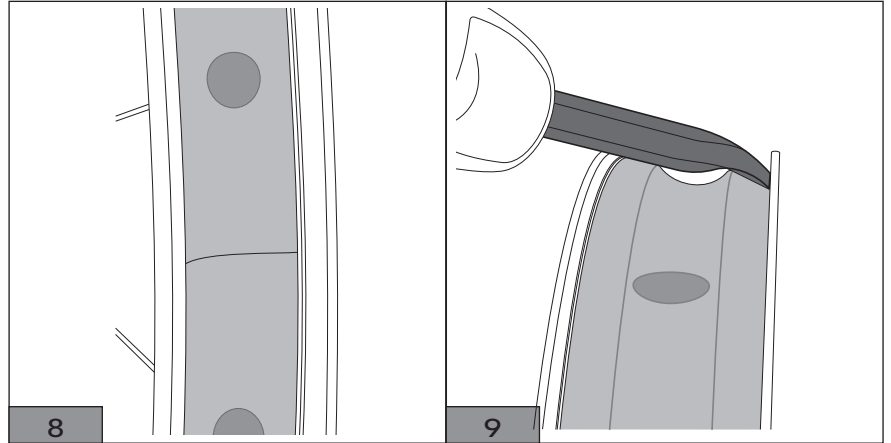

- Run your fingers over the tape to press out any air bubbles and check that the tape is completely adhered to the rim. Using the tool normally used to demount the tyre, press the edges of the tape along the bases of the inner side walls of the rim (Fig. 9).

- Using a cutter, make an X cut on the valve hole without reaching the edge of the hole itself (Fig.10).

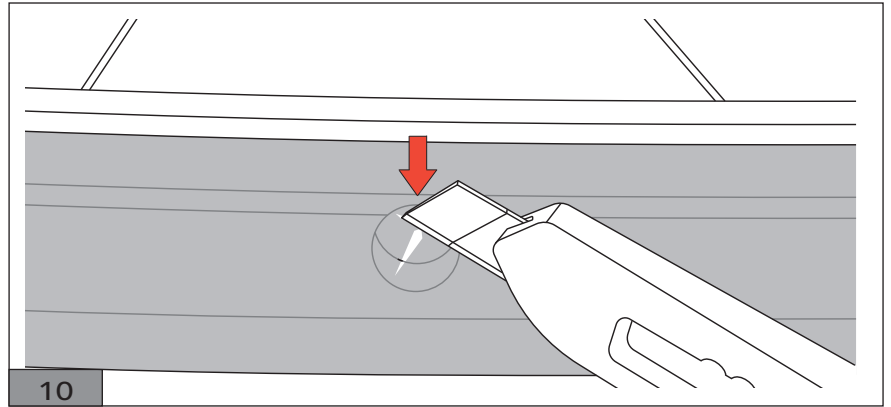

**⚠ WARNING!**

Be very careful not to damage the rim surface with the blade of the cutter in order to conserve the anodization rim treatment. This prevents oxidation, which can reduce the life of the rim due to fatigue.

- Insert the valve in the hole and block it using the knurled nut (Fig.11).

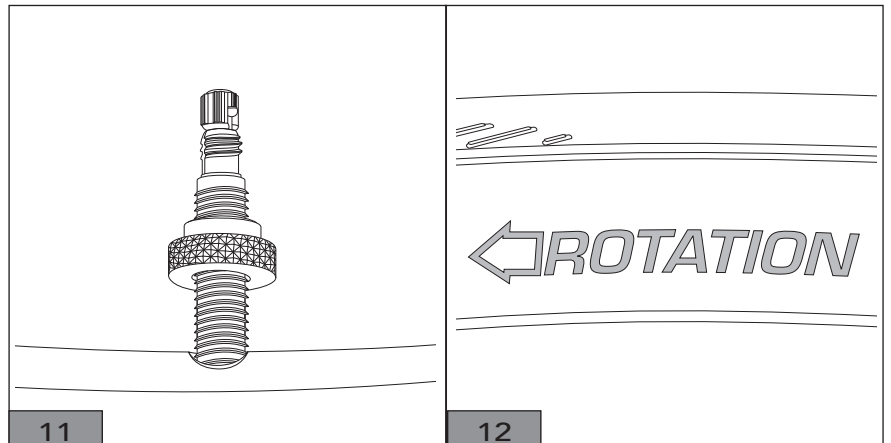

- Observe the rotation direction on the tyre (Fig.12).

## 2-WAY FIT™ READY TRANSFORMATION PROCEDURE

UNIT	REVISION	DESCRIPTION
ROAD WHEELS - DISC BRAKE	02 - 08 /2018	PROCEDURE FOR TRANSFORMING THE WHEELS INTO THE TUBELESS READY VERSION
PRODUCTS TO WHICH THIS PROCEDURE APPLIES		
SCIROCCO DB		<b>PAG.4</b>

- Fit a tyre bead into the central channel of the rim (Fig.13).
- Fit a second tyre bead, starting from the opposite side of the valve (Fig.14).

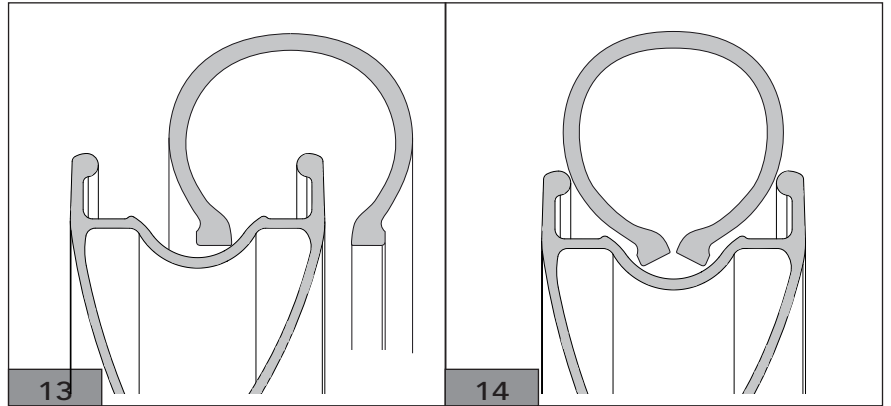

- Dip a brush (diameter approx. 2 cm) in a container of water and neutral soap, and apply plenty of water to the tyre beads (Fig.15).
- Check the valve is fully open (Fig.16).

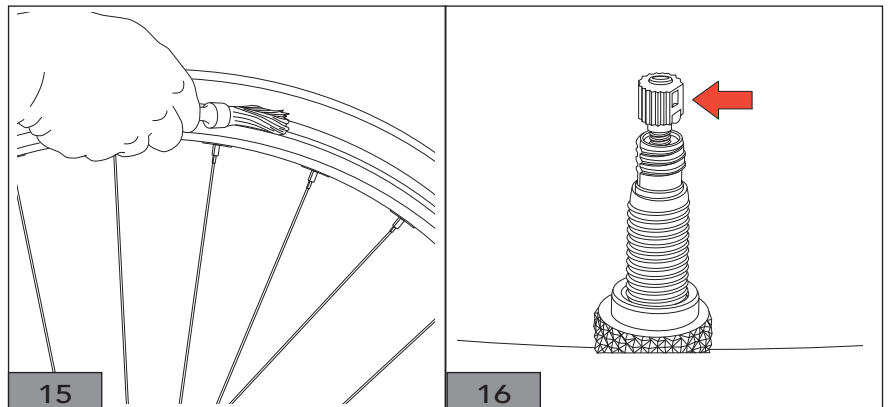

- Inflate the tyre without exceeding the maximum pressure indicated on the tyre, using a compressor or a pump, so the tyre bead is seated on the edge of the rim.

**⚠ DANGER!**

**Never exceed the maximum pressure indicated on the tyre. Pressure above this level could cause the wheel to burst suddenly, causing accidents, physical injury or death.**

- Carefully check that the tyre beads are correctly placed on the rim in a uniform manner along the entire circumference of the wheel.
- Deflate the tyre by pressing on the top part of the valve and prepare the tyre sealant liquid according to the manufacturer's instructions.

## 2-WAY FIT™ READY TRANSFORMATION PROCEDURE

UNIT	REVISION	DESCRIPTION
ROAD WHEELS - DISC BRAKE	02 - 08 /2018	PROCEDURE FOR TRANSFORMING THE WHEELS INTO THE TUBELESS READY VERSION
PRODUCTS TO WHICH THIS PROCEDURE APPLIES		
SCIROCCO DB		<b>PAG.5</b>

- Prop up the wheel, holding it in a vertical position with the valve on the uppermost point (Fig.17).

- If you are able to insert the liquid using a syringe: remove the central part of the valve using a suitable tool, insert the quantity of liquid suggested by the manufacturer and reinstall the central part of the valve (Fig.18).

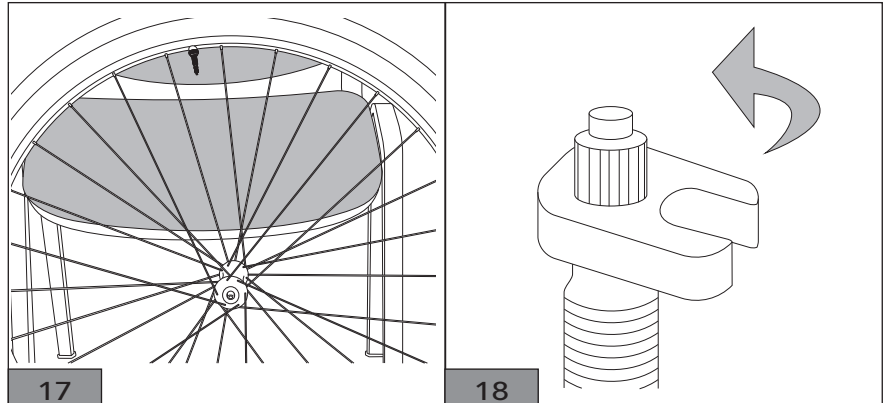

- If you do not have a syringe, unseat the beads on one side of the tyre, pour in the liquid, inserting the quantity suggested by the liquid manufacturer, and reposition the bead in the central channel of the rim (Fig. 19).

- Reinflate the tyre without exceeding the maximum pressure indicated on the tyre and carefully check that the tyre beads are correctly placed on the rim in a uniform manner along the entire circumference of the wheel.

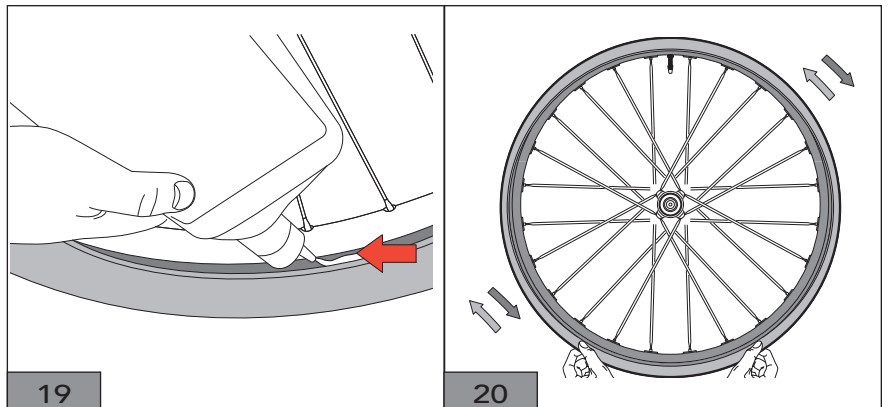

**⚠ DANGER!**

**Never exceed the maximum pressure indicated on the tyre. Pressure above this level could cause the wheel to burst suddenly, causing accidents, physical injury or death.**

- Rotate and shake the wheel so the liquid can seal all its inner surface. Apply water and soap on the cover and check for any bubbles, which would indicate air leaking from the cover. Position the wheel so that the liquid will flow to the area of the air leak, so the liquid can block it (Fig.20).

## 2-WAY FIT™ READY TRANSFORMATION PROCEDURE

UNIT	REVISION	DESCRIPTION
ROAD WHEELS - DISC BRAKE	02 - 08 /2018	PROCEDURE FOR TRANSFORMING THE WHEELS INTO THE TUBELESS READY VERSION
PRODUCTS TO WHICH THIS PROCEDURE APPLIES		
SCIROCCO DB		<b>PAG.6</b>

### Table of Schwalbe tyres approved for the 2-Way Fit Ready procedure

MODEL	VERSION	SIZE	ITEM CODE
Schwalbe G-One Speed	Microskin, TLE, V-Guard	40-584	11600997
		30-622	11600951
		35-622	11601054
		40-622	11600995
Schwalbe G-One Allround	Microskin, TLE	40-584	11600972.01
		35-622	11600764.01
		40-622	11600766.01
Schwalbe G-One Bite	Microskin, TLE	40-584	11601094
		40-622	11601003
Schwalbe X-One Allround	Microskin, TLE	33-584	11600959
		33-622	11601006
		35-622	11601005
Schwalbe X-One Speed	Microskin, TLE	33-622	11600956
Schwalbe X-One Bite	Microskin, TLE	33-622	11600922

MODEL	VERSION	SIZE	ITEM CODE
Schwalbe Pro One	Microskin, TLE	23-622	11600808
		25-622	11600809
		28-622	11600810
		30-622	11653989
Schwalbe One	RaceGuard, TLE	25-622	11601117.01